

SAFETY, MAINTENANCE AND MOUNTING INSTRUCTIONS

CESI 13 ATEX 033X IECEx CES 13.0013X
/ CML 22 UKEX1183X
GLANDS TYPES

ORION LEAD SHEATHED
KBA...-LSK



Rev.02

2 TECHNICAL SPECIFICATION TABLE

Types	Sizes		Group		Body Material			Temperature ¹	
	from	to	Group I	Group II Group III	Brass Stainless Steel Galvanized Steel	Aluminium	Chloroprene	Silicone ²	
KBA-LSK	M20	M90	NO	YES	YES	NO	-40°C to +100°C	-60°C to +130°C	
	M20	M90	YES	NO	YES	NO	-40°C to +80°C	-60°C to +80°C	
	M25	M75	NO	YES	NO	YES	-40°C to +80°C	-60°C to +80°C	
KBA-LSK	1/2"	3"	NO	YES	YES	NO	-40°C to +100°C	-60°C to +130°C	
	1/2"	3"	YES	NO	NO	YES	-40°C to +80°C	-60°C to +80°C	
	3/4"	2 1/2"	NO	YES	NO	YES	-40°C to +80°C	-60°C to +80°C	

¹Cable glands made of galvanized steel can be used up to -20°C.
²Min. temperature is limited by -50°C when the gland is used with fiber washer.

PRODUCTS PARTS

Orion Ex d/e Gland
KBA...-LSK



- Grounding Cone
- Grounding Spring
- Metal Washer

CONTENTS

- 1 MARKINGS and APPLICABLE STANDARDS
- 2 TECHNICAL SPECIFICATION TABLE AND PRODUCT PARTS
- 3 MOUNTING INSTRUCTION KBA...-LSK
- 4 IP PROTECTION for NON-THREADED HOLE
- 5 IP PROTECTION for THREADED HOLE
- 6 PREPARATION OF LEAD SHEATHED CABLE
- 7 SAFETY INSTRUCTION
- 8 ORION (KBA...-LSK) SIZE TABLE
- 9 EU AND UK DECLARATION OF CONFORMITY

1 MARKINGS AND APPLICABLE STANDARDS

MARKINGS

KBA...-LSK	GROUP I	CE 0722	II M2 Ex db I Mb Ex eb I Mb IP66/68 Ta -40°C to +80°C CESI 13 ATEX 033X IECEx CES 13.0013X
	GROUP II	CE 0722	II 2GD Ex db IIC Gb Ex eb IIC Gb Ex Ib IIC Db Ta -60°C to +130°C IP66/68 CESI 13 ATEX 033X IECExCES 13.0013X

APPLICABLE STANDARDS

DIRECTIVE 2014/34/EU	SI 2016 No. 1107 (amended by SI 2019 No.696)	
EN IEC 60079-0:2018	IEC 60079-0:2017 Ed.7.0	IEC 60529:1989
EN IEC 60079-7:2015+A1:2018	IEC 60079-1:2014-06 Ed.7.0	EN 60529:1991
EN 60079-1:2014	IEC 60079-7:2017 Ed.5.1	
EN 60079-31:2014	IEC 60079-31:2013 Ed.2	

3 MOUNTING INSTRUCTION KBA...-LSK



- Step 1** Choose the optimal cable according to clamping ranges submitted in the certificate and prepare the cable for installation. All Sub-Parts required for installation are shown respectively above.
- Step 2** Separate lower body and upper body from each other so that ensure the grounding cone is visible in the lower body. Mount the lower body to the appropriate opening on enclosure and tighten with sufficient torque value. Use locknut to tighten if the enclosure is non-threaded.
- Step 3** Insert the cable to the inside of upper body and then mount with lower body as shown. Ensure that Armours of the cable remains above the grounding cone.
- Note:** For lead sheathed cable, the lead sheath must pass through the grounding spring when installation is complete. The grounding spring on KBA Glands will automatically engage the lead sheath.
- Step 4** Tighten the upper body with sufficient torque value. For torque values please refer the tables "Sizes and torque of cable glands". Visually check if armour is securely clamped. If not, repeat the clamping process.

4 IP PROTECTION for NON-THREADED HOLES

Recommended Hole Diameters For Non Threaded enclosure applications in relation with the used thread types are shown below.

- For non-threaded enclosures it is recommended to use flat washer, between the gland body and enclosure.
- The recommended wall thickness is 1,5 mm for non threaded enclosures.
- In case of enclosure wall thickness is equal or lower than 1,5 mm, Bimetal flat washer should be used. Oring can stay in the channel if it is necessary. During the assembly it is recommended to rotate the locknut. If the assembly needs to be done by rotating the gland, then oring should be preferred.

Metric Threads		G Threads (GAS ISO 228/1)		PG Threads	
Thread	Hole Diameter (min. - max. mm)	Thread	Hole Diameter (min. - max. mm)	Thread	Hole Diameter (min. - max. mm)
M20 x 1.5	Ø20.0 - 20.2	G 1/4"	Ø13.2 - 13.4	PG 7	Ø12.5 - 12.7
M25 x 1.5	Ø25.0 - 25.2	G 3/8"	Ø16.6 - 16.8	PG 9	Ø15.2 - 15.4
M32 x 1.5	Ø32.0 - 32.3	G 1/2"	Ø21.0 - 21.2	PG 11	Ø18.6 - 18.8
M40 x 1.5	Ø40.0 - 40.3	G 3/4"	Ø26.4 - 26.6	PG 13,5	Ø20.4 - 20.6
M50 x 1.5	Ø50.0 - 50.3	G 1"	Ø33.3 - 33.6	PG 16	Ø22.5 - 22.7
M63 x 1.5	Ø63.0 - 63.3	G 1 1/4"	Ø41.9 - 42.2	PG 21	Ø28.3 - 28.5
M75 x 1.5	Ø75.0 - 75.3	G 1 1/2"	Ø47.8 - 48.1	PG 29	Ø37.0 - 37.3
M90 x 1.5	Ø90.0 - 90.3	G 2"	Ø59.6 - 59.9	PG 36	Ø47.0 - 47.3
M90x 2.0	Ø90.0 - 90.3	G 2 1/2"	Ø75.2 - 75.5	PG 42	Ø54.0 - 54.3
M100 x 2.0	Ø100.0 - 100.3	G 3"	Ø87.9 - 88.2	PG 48	Ø59.3 - 59.6
		G 3 1/2"	Ø100.4 - 100.7		
		G 4"	Ø113.1 - 113.4		
		G 5"	Ø138.5 - 138.8		

5 IP PROTECTION for THREADED HOLES

Ingress Protection: In order to guarantee the specified IP66/68 rating, sealant agent shall be applied on at least two full threads before fitting the gland to the box. In any case you must pay attention to guarantee the metallic continuity. For threaded enclosures min. wall thickness must be equal to the thickness of the relevant locknut.

IP Protection for Cylindrical Threaded Joints

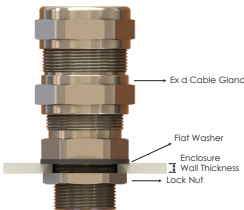

Ex d Execution:
 - Assemble the gland with o-ring or flat washer through the threaded hole.
 - The wall has to be thick enough to engage at least 5 full threads.
 - The minimum engaged thread depth must be at least 8 mm.

Ex e & Ex Ib Execution:

- Assemble the gland with o-ring or flat washer through the threaded hole.
 - You have to respect the minimum wall thickness of 1,5 mm.

IP Protection for Tapered Threaded Joints

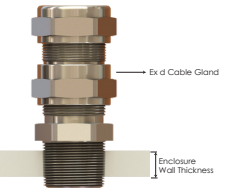

Ex d Execution:

- The wall has to be thick enough to engage at least 5 full threads.

Ex e & Ex Ib Execution:

- For Ex Ib applications please refer to NPT ANSI B1.20.1 standart.

NPT	Minimum Engaged Thread Depth	
	mm	inch
1/4	7,055	0,277
3/8	7,055	0,277
1/2	9,070	0,357
3/4	9,070	0,357
1	11,045	0,434
1 1/4	11,045	0,434
1 1/2	11,045	0,434
2	11,045	0,434
2 1/2	15,875	0,625
3	15,875	0,625
4	15,875	0,625
5	15,875	0,625

6 PREPARATION OF LEAD SHEATHED CABLE

- Please refer to the figure below, for details about the preparation of wire armoured cables for fitting into the cable gland.

Composition of armour - h min. = height (h1) of armour tightening cone + 2 mm max.

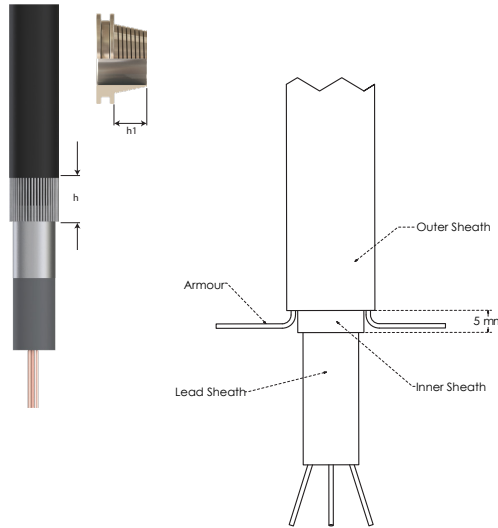

7 SAFETY INSTRUCTION

- Qualified personnel in compliance with the national laws shall carry out the maintenance in accordance with EN/IEC 60079-17 and installation in accordance with EN/IEC 60079-14.
- Changes to products are not allowed.
- Only bimed spare parts must be used.
- The maintenance operations must be carried out only after the engine has been cut off from mains or from the related electrical appliance.
- The following instructions must be strictly followed in order to get a correct installation.
- The national safety rules and accident prevention regulations, must be strictly respected.
- The clamping of the cables must be realised outside of enclosure by appropriate torque values to guarantee the mechanical characteristics.
- The cable glands can be used with Ex i circuits.
- The cable glands are only suitable for fixed installations. Cables shall be effectively clamped to prevent pulling or twisting.
- The cable gland installation shall be done according to safety manufacturer instructions to maintain degree of protection.
- Cable gland installation shall be done taking into account the temperature range declared for cable glands in relation to protection mode execution, versus the ambient temperature proper of installation.
- The certificate does not indicate compliance with electrical safety and performance requirements other than those expressly included in the Standards listed in the first page of the manual.
- The certificate does not cover hazards coming from environmental conditions different from those clearly and precisely indicated in clause 1 of EN 60079-0.
- Service temperature of the gland is related to the material of the sealing ring but can additionally be limited by the material of the flat washer/oring/accessories.

8 ORION (KBA...-LSK) SIZE TABLE

Cable Gland Type	Size TD ISO Pitch 1,5	Clamping Range		Torque of cable glands [Nm]	
		Lead Sheath min-max	Outer Sheath min-max	SW 2	SW 3
KBA1SM-LSK	M20x1.5	3,0-8,0	6,0-12,0	27	25
KBA1M-LSK	M20x1.5	6,0-11,5	8,5-16,0	49	28
KBA11M-LSK	M20x1.5	8,5-14,0	12,0-20,0	35	28
KBA2XSM-LSK	M25x1.5	3,0-8,0	6,0-12,0	27	25
KBA2SM-LSK	M25x1.5	6,0-11,5	8,5-16,0	49	28
KBA2M-LSK	M25x1.5	8,5-15,0	12,0-21,0	32	26
KBA2LM-LSK	M25x1.5	12,0-19,0	16,0-26,0	61	32
KBA3XSM-LSK	M32x1.5	6,0-11,5	8,5-16,0	49	28
KBA3SM-LSK	M32x1.5	12,0-19,0	16,0-26,0	61	32
KBA3M-LSK	M32x1.5	15,0-25,0	20,0-33,0	86	40
KBA4XSM-LSK	M40x1.5	12,0-19,0	16,0-26,0	61	32
KBA4SM-LSK	M40x1.5	15,0-25,0	20,0-33,0	86	40
KBA4M-LSK	M40x1.5	20,0-31,0	29,0-41,0	110	75
KBA5XSM-LSK	M50x1.5	15,0-25,0	20,0-33,0	86	40
KBA5MM-LSK	M50x1.5	20,0-31,0	29,0-41,0	110	75
KBA5SM-LSK	M50x1.5	22,0-34,0	33,0-48,0	110	75
KBA5M-LSK	M50x1.5	27,0-40,0	36,0-52,0	125	75
KBA6XSM-LSK	M63x1.5	22,0-35,0	33,0-48,0	110	75
KBA6MM-LSK	M63x1.5	27,0-40,0	36,0-52,0	125	75
KBA6SM-LSK	M63x1.5	35,0-44,0	43,0-57,0	160	140
KBA6M-LSK	M63x1.5	40,0-50,0	47,0-60,0	250	100
KBA6LM-LSK	M63x1.5	45,0-56,0	54,0-70,0	250	150
KBA7XSM-LSK	M75x1.5	35,0-44,0	43,0-57,0	160	140
KBA7SM-LSK	M75x1.5	40,0-50,0	47,0-60,0	250	100
KBA7M-LSK	M75x1.5	45,0-58,0	54,0-70,0	250	150
KBA8XSM-LSK	M90x1.5	40,0-50,0	47,0-60,0	250	100
KBA8SM-LSK	M90x1.5	45,0-58,0	54,0-70,0	250	150
KBA8M-LSK	M90x1.5	60,0-70,0	63,0-80,0	320	210

9 EU DECLARATION OF CONFORMITY



EU DECLARATION OF CONFORMITY

bimed

Bimed Teknik Aletler San. ve Tic. A.Ş.
 Özar Sanayi Bölgesi, Delialıkaya Mh. Yüzbaşı Mehmet Hilmi Cd. No:281 Amavutköy -
 İstanbul-TÜRKİYE Tel: +90 212 8757376 Fax: +90 212 8750823

declares that the products designed to be placed on the market for use in the explosive atmospheres described below are in conformity with the listed EU Directive and harmonized standards.

Cable Gland Types: KBA-LSK
 Certificate Number: CESI 13 ATEX 033X
 Protection Type: Ⓜ 1M2 / II 2 GD; Ex db 1Mb; Ex eb 1Mb; Ex db IIC Gb; Ex eb IIC Gb; Ex db IIIC Db IP66/68

EU Directive: ATEX 2014/34/EU
 The harmonized standards applied: EN IEC 60079-0:2018
 EN 60079-1:2014
 EN IEC 60079-7:2015/A1:2018
 EN 60079-31:2014

The compliance of the equipment is not affected by the modifications introduced by harmonized standard

EN IEC 60079-7:2015/A1:2018
 EN IEC 60079-0:2018

Notified body CESI 0722

Istanbul, 03.10.2025

General Manager
 Yakup Gültekin
 YAKUP GULTEKIN
 T.C. EKİŞİ VE İZMİR
 SANAYİ VE TİCARET

rev:01

9 UK DECLARATION OF CONFORMITY



UK DECLARATION OF CONFORMITY

bimed

Bimed Teknik Aletler San. ve Tic. A.Ş.
 Özar Sanayi Bölgesi, Delialıkaya Mh. Yüzbaşı Mehmet Hilmi Cd. No:281 Amavutköy -
 İstanbul-TÜRKİYE Tel: +90 212 8757376 Fax: +90 212 8750823

declares that the products designed to be placed on the market for use in the explosive atmospheres described below are in conformity with the listed UK Directive and designated standards.

Cable Gland Types: KBA-LSK
 Certificate Number: CML 22 UKEX1183X
 Protection Type: Ⓜ 1M2 / II 2 GD; Ex db 1Mb; Ex eb 1Mb; Ex db IIC Gb; Ex eb IIC Gb; Ex db IIIC Db IP66/68

UK Directive: SI 2016/306 1197 (amended by SI 2019/346 496)
 The designated standards applied: EN IEC 60079-0:2018
 EN 60079-1:2014
 EN 60079-7:2015/A1:2018
 EN 60079-31:2014

Approved body CML 2503

Istanbul, 03.10.2025

General Manager
 Yakup Gültekin
 YAKUP GULTEKIN
 T.C. EKİŞİ VE İZMİR
 SANAYİ VE TİCARET

rev:01